

TRAILER - 1 SIDE DOOR - CURB SIDE

KWIK ZIP FRAME MEASURING PROTOCOL



Once completed, please fax or email to:

E-MAIL: epicmeasurements@epicworldwide.com

FAX: (702) 614-9900

SALES ORDER # _____

COMPANY: _____

CONTACT: _____

ADDRESS: _____

CITY: _____

E-MAIL: _____

PHONE: _____

COMMENTS: _____

TRUCK/TRAILER INFORMATION

UNIT #	VIN #	
LIC. #	MAKE	YEAR BUILT
Measured By	Date	

INSTRUCTIONS

Draw any hardware or damage that could interfere with the installation. Complete in Feet, Inches and Fractions to the 1/8"

Example:

7	5	3	8
Ft	In	Frac	

DO WE NEED TO?

- REMOVE EXISTING DECAL
- RELOCATE CONSPICUITY TAPE
- RELOCATE HAZMAT SIGNS

VERY IMPORTANT - PLEASE ANSWER

REAR DOOR
LIFT GATE?

- YES
- NO

SURFACE TYPE

- CORRUGATED - HORIZONTAL RIBS
- ALUMINUM - LOTS OF RIVETS
- FRP - FEWER RIVETS
- COMPOSITE - DURAPLATE OR Z-PLATE

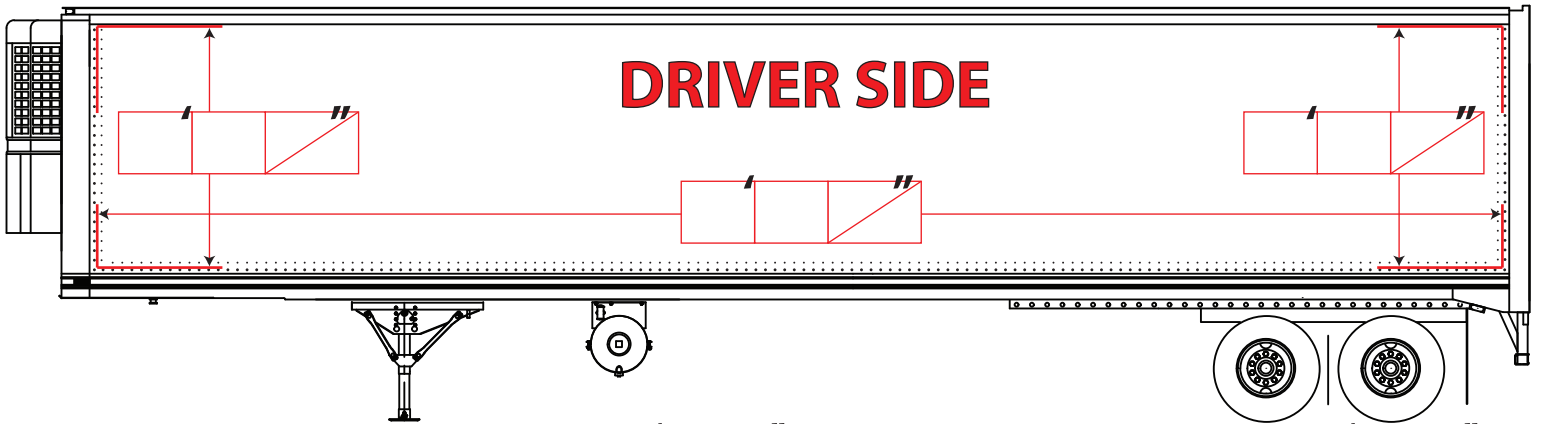
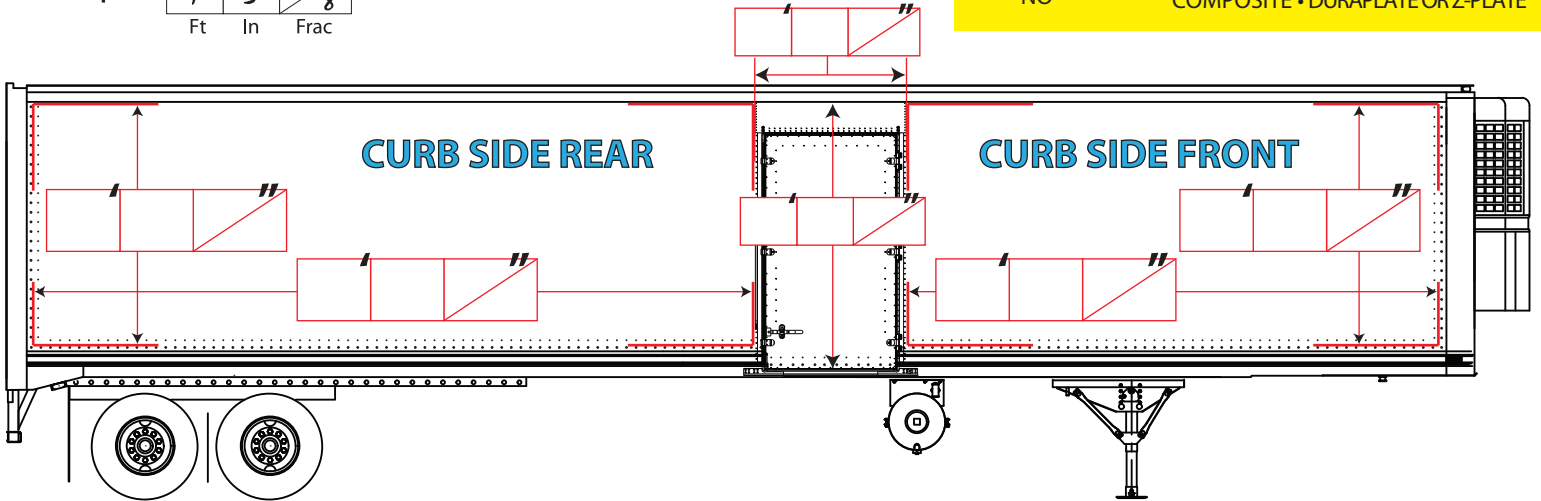

REAR DOOR

ROLL UP

SWING

YES

- REMOVE EXISTING DECAL
- RELOCATE CONSPICUITY TAPE
- RELOCATE HAZMAT SIGNS
- PAINT DAMAGE
- WOOD PANEL DAMAGE
- PREP-WORK NEEDED

